

Multi-Sensor Single-Actuator Control of HVAC Systems

Craig Lin¹, Clifford C. Federspiel², David M. Auslander¹

¹Department of Mechanical Engineering, University of California, Berkeley

²Center for the Built Environment, University of California, Berkeley

Abstract

It is common to control several rooms in a building with a single sensor in one of the rooms and a single actuator driving just one control element such as an air damper. New, low-cost, wireless sensor technology now offers the opportunity to replace the single sensor in one room with a network of sensors where there is at least one sensor per room. This paper addresses this multi-sensor, single-actuator control problem. We used computer simulations and optimization to study the problem. We designed a computer simulation of the heat transfer behavior of a section of a building that accounted for the effects of weather, building materials, ventilation, and loads from occupants and equipment. We considered ad hoc methods (such as averaging) of using information from multiple sensors. We also developed a new, model-free method of using information from multiple sensors that is based on a simple optimization procedure. The optimization procedure can be configured to optimize comfort or to optimize energy under comfort constraints. We compared the performance of the single-sensor strategy with the ad hoc strategies and optimized strategies using annual simulations of a four-room, perimeter section of a building and weather data from Sacramento, California. We report heating and cooling energy performance along with two comfort metrics, the average number of rooms within the ASHRAE comfort zone and the Predicted Percentage Dissatisfied (PDD). The results show that most of the multi-sensor control strategies do better than the single-sensor strategy on the basis of both energy performance and comfort. The energy-optimal strategy reduces energy consumption by 17% while reducing PDD from 30% to 24%. The comfort-optimal strategy reduces energy consumption by 4% while reducing PDD from 30% to 20%. The performance improvements occur primarily when the average load among all rooms is nearly zero, with some rooms requiring heating while others require cooling. Under these conditions, the single-sensor strategy either overcools or overheats, whereas the multi-sensor strategies use almost no energy.

Keywords: sensor; HVAC; control system; optimization; multi-channel sensing system;

I. Introduction

In commercial buildings it is common to control multiple spaces or rooms with a single heating, ventilating, and air-conditioning (HVAC) unit and controller. Systems configured this way are most commonly controlled with a single sensor in one of the rooms. The controller gets the temperature reading from one room, and supplies heating or cooling to all other rooms proportionally. This method assumes that all rooms have the same load all the time, and therefore the same temperature throughout. This is often a poor assumption, which leads to discomfort and more energy consumption than necessary.

The reason for controlling multiple rooms with a single controller and a single sensor is cost. It is expensive to install a separate HVAC unit and controller for each room. It is also expensive to install temperature sensors in every room, primarily because of the cost of running wire to the sensors.

New technology, particularly wireless sensor technology, offers the opportunity to significantly reduce the cost of sensors such as those used to control space temperature in commercial buildings. However, the actuation parts of the system will still be expensive for the foreseeable future.

In this paper, we investigate the potential benefit of replacing a single temperature sensor used to control a set of rooms with a sensor network that provides one sensor per room. However, we do not change the actuation. There is still just one controller and one HVAC unit for the set of rooms. To our knowledge, the energy and comfort implications of this problem have not been analyzed. Most multiple sensor control problems have focused on fault tolerance (Hsu et al., 1995; Shamseldin et al., 2000) or multi-target problems (Rothrock and Drummond, 2000; Malis et al., 2001). The problem that we address in this paper is like a multi-target problem where not all of the targets can be satisfied since we only have one actuator.

The focus of the paper is on how to make use of the additional information available from a network of sensors, and an evaluation of how different methods of using the information affect energy performance and thermal comfort. We investigated simple, ad hoc methods and developed a new method that is based on an optimization procedure. The optimization procedure is designed to be independent of the HVAC system or any model of the HVAC system so that it is easy to apply to a wide variety of systems. It can be aimed at optimizing comfort, or minimizing energy consumption subject to constraints on comfort.

The next section describes the mathematical model of the building, HVAC system, and controls that formed the basis of our computer simulations. The subsequent section describes the thermal comfort penalty function that we used in our computer simulations. Section 4 describes the different methods that we investigated for using sensor information. Results of the computer simulations are in Section 5.

II. Modeling

To experiment with computer simulations, we developed a mathematical model of a section of a building. The building model includes the effects of air exchange, conduction through walls and fenestration, solar radiation, energy storage in furniture, and internal loads from occupants and equipment. It can predict both transient and static behavior of the system. The model is modular so that we can easily replace some elements with others and make the number the rooms adjustable.

Figure 1 shows a schematic diagram of a single room. The figure shows the relevant heat transfer terms in the model. A single room has six modules: external wall, internal wall, window, ceiling, floor, and air. These walls have multiple layers. Each room has three heat transfer inputs: internal loads, outdoor temperature, and the temperature of adjacent spaces. This model has been used by Martin et al., (2002) for building control system simulation.

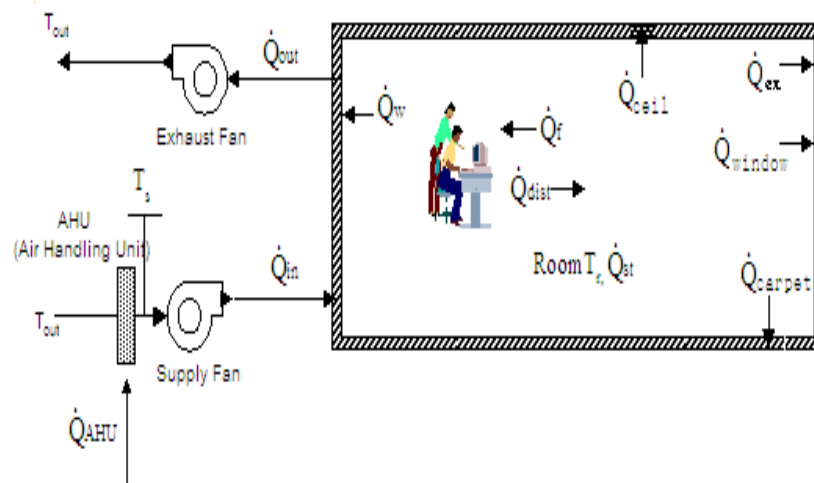

Figure 1: Schematic diagram of single room showing heat transfer terms.

III. Comfort

To optimize the use of sensor information, we need a (dis)-comfort metric. This metric is used as a penalty function.

Thermal comfort is affected by a number of variables including temperature, humidity, clothing insulation, air velocity, etc. It is also affected by dynamic behavior such as the rate of change of temperature. To simplify the complex relationship between environmental factors and comfort, we assumed that all environmental factors other than temperature and clothing are constant. We make a clothing adjustment based on the season. We used the Predicted Percentage Dissatisfied (PPD) as the discomfort penalty function. In order to obtain PPD as a function of temperature, we computed the PMV

index as a function of temperature first. See Fanger (1972) for details regarding PPD and PMV.

We used the following function to compute PMV as a function of clothing and temperature:

$$PMV = (-8.6479 + 0.2431 * C) + (0.3442 - 0.0073 * C) * T_{air} \quad (1)$$

where C denotes the month of the year and T_{air} denotes air temperature in degree C. The value of C is zero during the coldest month and 11 during the hottest month. The coefficients in Equation 1 were derived from the original PMV function.

We used the following function to compute PPD as a function of PMV:

$$PPD = 100 - 95 \exp\left[-\left(0.03353 PMV^4 + 0.2179 PMV^2\right)\right] \quad (2)$$

This function is an approximation. The original PPD function is the sum of two normally distributed probability distribution functions.

The ASHRAE comfort zone is defined as the range of conditions that give 10% dissatisfaction. We used the comfort zone to establish a tradeoff between discomfort and energy consumption. When the temperature was in the comfort zone, we ignored the PPD penalty. When the temperature was outside the comfort zone, we set the discomfort penalty equal to $0.9(PPD - 0.1)$. Doing so results in a flat-bottomed discomfort penalty. We used this flat-bottomed discomfort penalty to design “optimal” strategies for using information from multiple sensors. However, when evaluating performance, we used PPD to evaluate performance.

IV. Control strategies

We compared a number of control strategies with the base case, which is control based on a single sensor in one of a set of rooms served by the single actuation unit. We report the results of three ad hoc strategies and a new strategy that involves a simple optimization procedure. The optimization procedure is designed to either minimize discomfort or to minimize energy consumption subject to a discomfort constraint. The details of these strategies are described below.

a) Single Sensor Case

In most buildings today, space temperature is controlled by regulating the temperature in one room served by the HVAC unit even if it serves more than one room. This sensor information is taken as the only information for the feedback loop. This method provides a low cost solution, but the comfort cannot be guaranteed. The more similar the rooms, the better this strategy works. However, even if the all rooms are physically similar and the HVAC is balanced properly, the transient nature of internal loads and solar loads in

each room can cause significant differences in the temperature from room to room.

b) Ad Hoc Multiple Sensor Strategies

There are several simple ways to combine information from a network of sensors. One method is averaging. Averaging is a linear operation, so it is relatively easy to analyze the expected behavior of this strategy. For the same reason, it is also easy to tune a control system that uses averaging. A variant of the averaging method is to use a weighted average. For example, large rooms could be weighted more than small rooms.

Another ad hoc method is control to control the worst-case room. In this strategy, the controller operates only on the temperature reading from the room that is the farthest in absolute value from the setpoint., switching rooms when another room becomes hotter or colder than the room being controlled. The purpose of this method is to try to make the room that is most uncomfortable as comfortable as possible.

The third ad hoc method we considered is to control the average of the hottest and coldest room. The concept with this strategy is to have a compromise between the first two strategies. This strategy attempts to make the most uncomfortable rooms as comfortable as possible, but it does so using a linear operation that doesn't involve switching.

c) Optimization Method

We developed a new method of using information from multiple sensors. It is based on an optimization procedure that accounts for comfort and energy. The concept behind the optimization method is to maximize the number of rooms in the ASHRAE comfort zone, and then either make those rooms outside the comfort zone as comfortable as possible or shift the temperature of the rooms in the comfort zone to save energy.

The first step is to determine the maximum number of rooms that can be put into the comfort zone. This is done by sorting the temperatures and searching for the difference between values in the list that is less than the ASHRAE comfort zone and that includes the most values.

The second step is to optimize comfort for rooms that are outside the comfort zone. Since the first step only determined the zone that can be put into the comfort zone, we still have some flexibility to minimize discomfort. If all of the rooms outside the comfort zone are too cold, we simply move the hottest room in the comfort zone to the upper limit of the comfort zone, thereby minimizing the discomfort of all rooms outside the comfort zone. We use a similar approach when all rooms outside the comfort zone are too hot. If some of the rooms outside the comfort zone are too cold while others are too hot, we need to find an optimal solution to the total comfort. In this case we take the modified PPD as our penalty function and do a golden section search that minimizes the total discomfort index based on the constraint that the maximum number of rooms are kept within the comfort zone.

If all rooms can be put within the comfort zone, we optimize for energy. When cooling, this means that we will control the hottest room to the upper limit of the comfort zone. When heating the coldest room is controlled to the lower limit of the comfort zone.

We developed an alternative optimization method that places more emphasis on energy savings. This method will use less energy, but will also result in more discomfort than the first optimization method. The method works as follows. First we maximize the number of rooms in the comfort zone as in the first step above. If all rooms can be placed in the comfort zone without heating or cooling, then we neither heat nor cool. Otherwise we shift the extreme temperature that is inside the comfort zone to the upper or lower limit of the comfort zone depending on whether or not cooling or heating is required.

V. Computer simulation

Matlab was used to compare the performance of the six control strategies based on comfort and energy performance. The simulations used the building model described in Section 2 and TMY2 weather data for Sacramento, CA. We report annual energy consumption and average annual discomfort. The simulator computes steady-state energy consumption and discomfort during normal business hours.

The building model included four perimeter rooms with the same external exposure. All rooms have the same width and height but different lengths. The internal loads were modeled as a pseudo-random step function to simulate people walking in and walking out of the rooms and turning equipment on and off.

We set the fraction of the total supply air delivered to each room equal to the ratio of the floor area in that room to the total floor area of all rooms. This balancing procedure accounted for the average differences in internal and external loads on each space.

We tested the single-sensor strategy with a sensor in each of the four rooms, the three ad hoc strategies (averaging, worst-case, average of max and min), and the two variants of the optimization method. We report the PPD without modification to assess comfort. We also report the average number of rooms in the comfort zone as a comfort metric. We computed heating energy and cooling energy separately. The cooling energy is the heat transfer rate at the room level. It does not take into account the energy conversion efficiency of a mechanical cooling system.

The results are shown in Table 1. Most of the multi-sensor methods outperform the average performance of the single-sensor method on the basis of both energy performance and comfort performance. The comfort optimization strategy produces the lowest average PPD. The energy optimization method uses the least amount of energy. Both optimization strategies result in the highest average number of rooms in the comfort zone, and both produce the same average number of rooms in the comfort zone because they have the same first step.

Table 1: Energy and comfort performance.

	Average Cooling Power (kW)	Average Heating Power (kW)	Rooms in Comfort Zone	PPD
Single sensor in room 1	14.26	8.61	1.6322	29.3099 %
Single sensor in room 2	14.43	8.21	1.6075	29.9569 %
Single sensor in room 3	13.89	7.80	1.6370	27.7661 %
Single sensor in room 4	15.17	8.07	1.5747	31.2659 %
Average of all single sensor cases	14.44	8.17	1.6129	29.5747%
Multiple sensor optimized for comfort	14.12	7.58	2.3712	20.1074 %
Multiple sensor optimized for energy	13.22	5.50	2.3712	23.9025 %
Average all sensors	13.92	7.07	1.1914	20.5462 %
Control the worst	20.29	13.3	1.4068	37.0071 %
Average highest and lowest	13.95	7.01	0.9360	23.0541 %

We also studied how variability of the load affects the energy and comfort performance. The difference of room size and wall mass among all rooms can be eliminated and the effects of the outside temperature could also be decreased to an acceptable level due to the supply flow balancing. Therefore, variable internal loads are the main cause of the temperature difference among rooms.

We ran the same simulation as above for different occupant densities. Since we model occupancy as a random process, we ran the simulation at each occupant density three times and took the average. We compared the results of the optimization methods to the average of single sensor case and plot the comfort improvement as well as energy saving. Figures 2-4 show the simulation results of our method optimized for comfort.

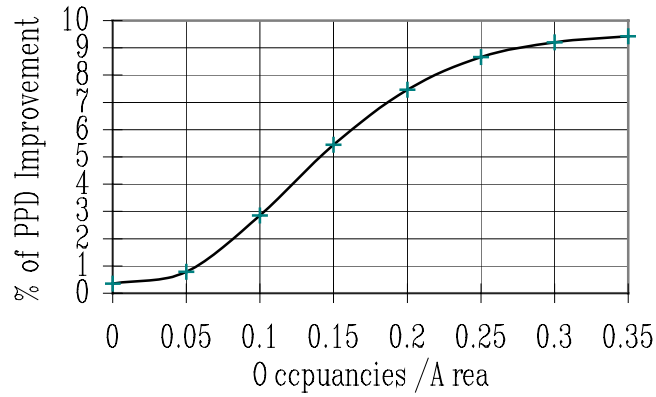

Figure 2: Comfort improvement for comfort-optimal strategy.

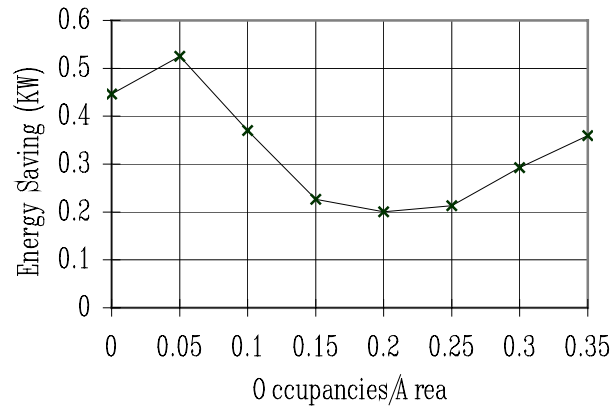

Figure 3: Cooling energy improvement for comfort-optimal strategy.

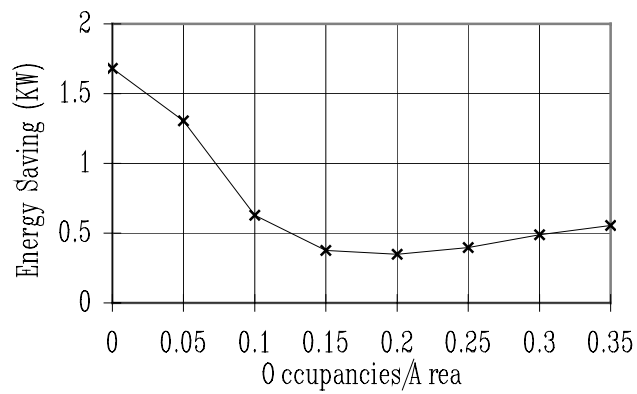

Figure 4: Heating energy improvement for comfort-optimal strategy.

As we could see from above results, the comfort improvement is increased significantly as occupancies increased for our method optimized for comfort. The energy saving won't increase but we still can always save energy than single sensor methods.

Figures 5-7 show how variability of the internal load affects the improvements of the energy optimization method. The figures illustrate that the energy optimization strategy yields less comfort improvement with increasing variability than the comfort optimization method but saves more energy. However, compared to the single sensor methods, we always improve comfort and save energy than at the same time.

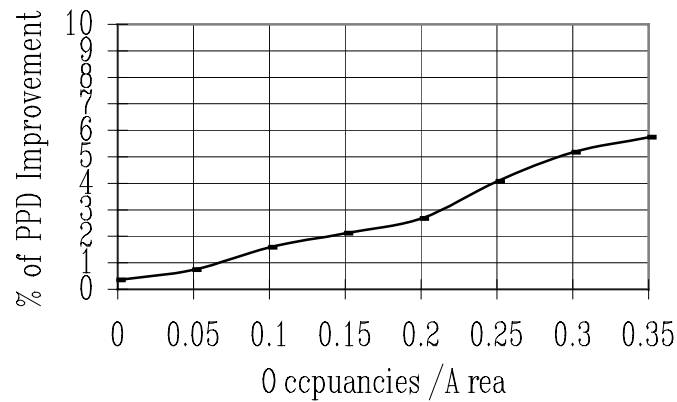

Figure 5: Comfort Improvement for energy-optimal strategy.

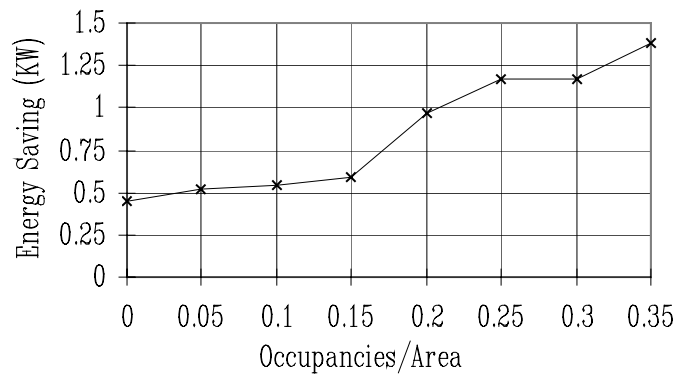

Figure 6: Cooling energy savings for energy-optimal strategy.

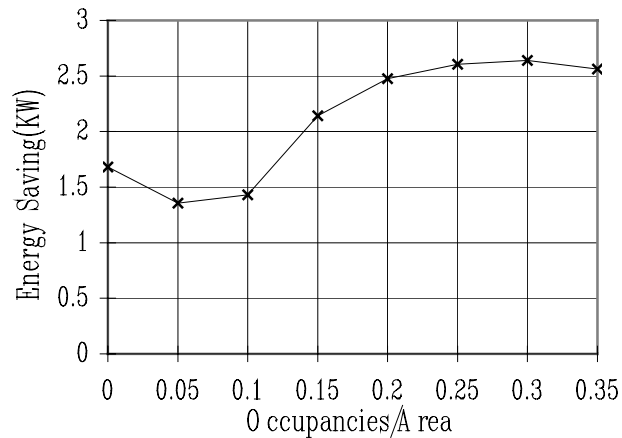

Figure 7: Heating energy savings for energy-optimal strategy.

VI. Discussion

This paper reports two significant findings regarding the use of multiple sensors for controlling systems with a single actuator. The first is that using multiple sensors can result in simultaneous energy savings and comfort improvement. The second is that not all strategies for using multiple sensors work better than a single sensor strategy.

For the averaging strategy we can show why it improves both energy and comfort performance. The improvement occurs when some rooms require heating while others require cooling. When all rooms require heating or all rooms require cooling, the averaging strategy produces the same energy and comfort performance as the average of the single-sensor strategies. When some rooms need heating while others need cooling, the single-sensor strategy uses heating energy or cooling energy and makes some of the rooms very uncomfortable. For example, if two rooms in a four-room HVAC zone need heating and the other two need cooling, and if the sensor is in a room that needs cooling, then the single-sensor strategy will use cooling energy and make the two rooms that need heating very uncomfortable. The averaging strategy will use no energy in this case and will induce significantly less discomfort in the rooms requiring heating. This discomfort reducing more than offsets the discomfort in the rooms requiring cooling because there is a nonlinear relationship between discomfort and temperature.

The results show that not all multi-sensor control strategies are better than single-sensor control. In particular, the strategy that controls the room with the temperature farthest from the setpoint is worse both on the basis of energy and comfort. This strategy switches back and forth repeatedly between heating and cooling which wastes energy. Controlling the single worst room also causes the average discomfort to be greater because more of the other rooms become somewhat uncomfortable.

VII. Conclusion

The conclusions regarding multi-sensor, single-actuator control of temperature in buildings are as follows:

1. Energy performance and comfort can be simultaneously improved by using multiple sensors.
2. Among ad hoc strategies tested, averaging all sensors or averaging the worst-case readings works best.
3. Switching strategies do not work well.
4. A new strategy that uses optimization works better than the ad hoc strategies and can be designed to either emphasize energy performance or comfort.

Reference:

Hsu P.L., K.L. Lin, and L.C. Shen, 1995, "Diagnosis of Multiple Sensor and Actuator Failures in Automotive Engines", *IEEE Transactions on Vehicular Technology* Vol 44 (4) 779-789 November 1995.

Shamseldin, A., B. J. Black, and E. O'Brien, 2000, "Multiple-sensor weigh-in-motion of road vehicles using a neural network algorithm.", *Computational Engineering Using Metaphors from Nature*, Leuven, Belgium 53-8. Sept. 2000.

Rothrock, R.L. and O. E. Drummond, 2000, "Performance metrics for multiple-sensor multiple-target tracking.", *Proceedings of the SPIE - The International Society for Optical Engineering*, vol.4048 521-31, 2000

Malis E., G. Morel, and F. Chaymette, 2001, "Robot control using disparate multiple sensors", *International Journal of Robotics Research*, 20(5), 364-377.

ASHRAE, *1997 ASHRAE Handbook Fundamentals*, Atlanta: ASHRAE

Martin, R. M., C. C. Federspiel, and D. M. Auslander, 2002, "Responding to Thermal Sensation Complaints in Buildings," *ASHRAE Transactions*, 112(1).